

断面図 A-A

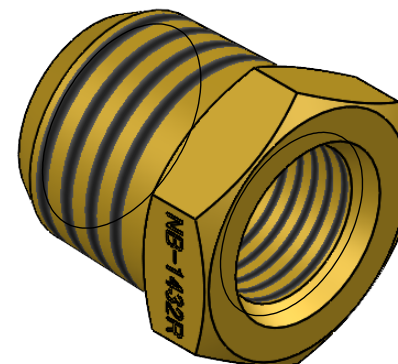
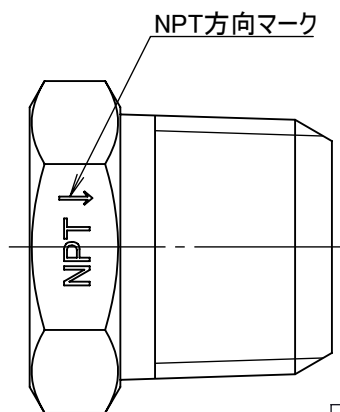
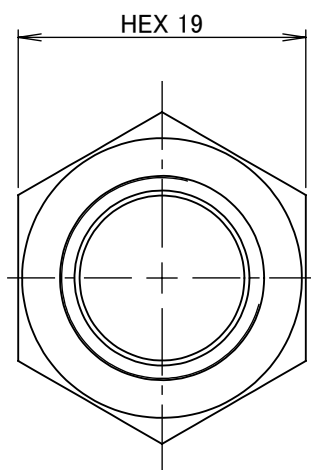
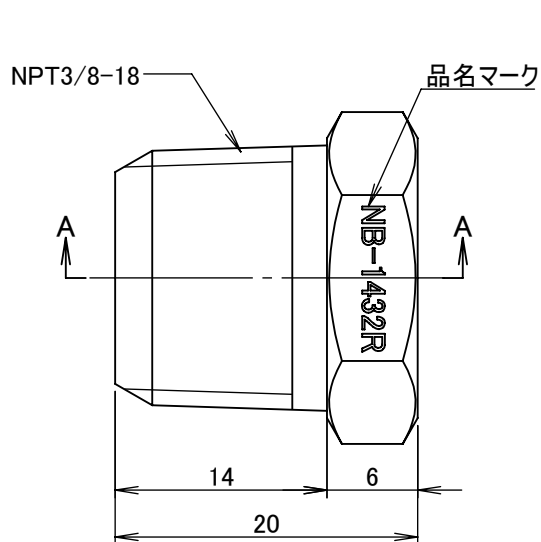

		第3角法	単位 mm	尺度 2:1	日付 2024/04/05
承認 水田	検図 水田	材質 C3604BD(cd75ppm以下)			
設計 水田	製図 恵良	備考			
 ASOH CO.,LTD.		品名・品番 変換ブッシング NPT3/8×Rc1/4・NB-1432			
		図番 5R-NB1432			